

# Check It™ Panel

## Operation & Maintenance Manual - 3 Phase Duplex

### Introduction

Before proceeding with the installation or operation of the control panel read all instructions thoroughly, as well as comply with all Federal, State and Local Codes, Regulations and Practices. The control panel must be installed by qualified personnel familiar with all applicable local electrical and mechanical codes. Refer to the National Electrical Code (NFPA 70). Failure to properly install and test this product can result in personal injury or equipment malfunction. All conduit connected to the panel must be sealed with conduit sealant to prevent moisture or gases from entering the panel. NEMA 1 enclosures are for indoor use only while NEMA 4X panel enclosures may be used indoor or outdoor. Refer to panel model nameplate on inside of door for enclosure rating. Note: If options are ordered that affect the number of floats, refer to the panel schematic for complete information.

### Safety Guidelines



1. DO NOT USE WITH FLAMMABLE OR EXPLOSIVE FLUIDS SUCH AS GASOLINE, FUEL OIL, KEROSENE, ETC. DO NOT USE IN EXPLOSIVE ATMOSPHERES. CONTROL PANEL SHOULD ONLY BE USED IN WATER AND WASTEWATER APPLICATIONS THAT ARE NOT RATED AS A HAZARDOUS LOCATION.
2. DO NOT WORK ON THE CONTROL PANEL WITH LIVE VOLTAGE APPLIED TO THE CONTROL PANEL WITH WET HANDS OR WHEN STANDING ON A WET SURFACE.
3. DISCONNECT ALL ELECTRICAL SERVICE BEFORE WORKING ON OR HANDLING THE CONTROL PANEL
4. INCOMING VOLTAGE MUST MATCH THE CONTROL PANEL VOLTAGE. REFER TO THE PANEL SCHEMATIC FOR COMPLETE INFORMATION.

### Installation of the Control Panel:

1. Determine mounting location for the control panel. If splicing is required between the level switches and the panel, we recommend an Alderon Junction box. CAUTION! Use conduit sealant and waterproof wire nuts for connections. Make sure all connections are water tight.
2. Determine conduit entrance locations on control panel and install per local codes. Check schematic and determine number of power sources required. Use conduit sealant on all conduits to prevent moisture and gases from entering control panel.
3. Connect control/alarm and pump power conductors to the proper terminals. The schematic and terminal blocks will be labeled for proper and terminal blocks will be labeled for proper connection.
4. Verify correct panel operation after installation of panel, power and level switches are complete.



# Check It™ Panel

## Operation & Maintenance Manual - 3 Phase Duplex

### Field Wiring Connections:

Check It series control panels are multi voltage. Set the transformer voltage to match incoming power voltage. Set the amperage on the motor protective switches to match the pump full load amps.

### Pump Power Configurations

Set transformer to match incoming voltage.

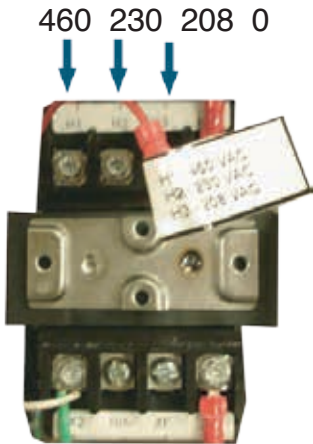

Set amps of each overload to match pump amps.



When panel is ready for operation, place the switch in the on position.

Connect incoming power and connect each pump.

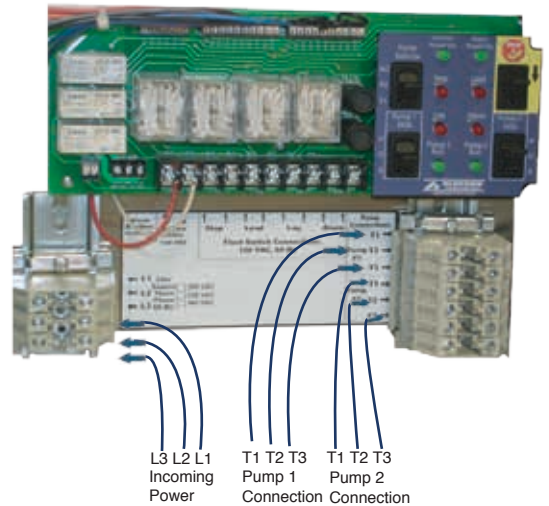

### Mounting Level Switches:

Float switches are most commonly used, but the Check It series control panels can be used with any dry contact type level or pressure switch. Illustrations show float switches installed for pump down applications. Reverse float order for Pump Up applications. Refer to float switch instructions for mounting of pipe clamp or weighted floats.

#### Connecting 3 float switches

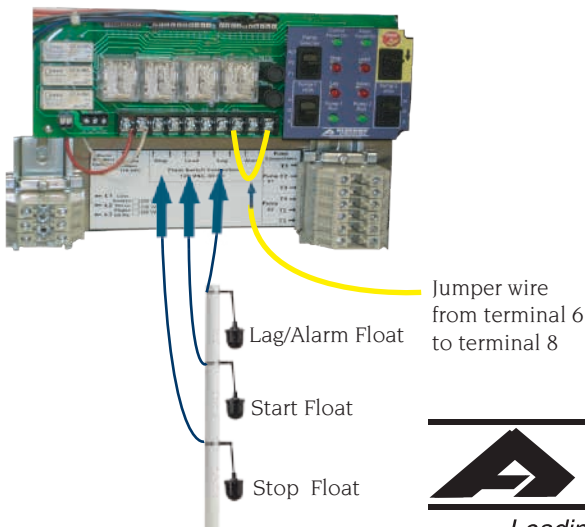

#### Connecting 4 float switches

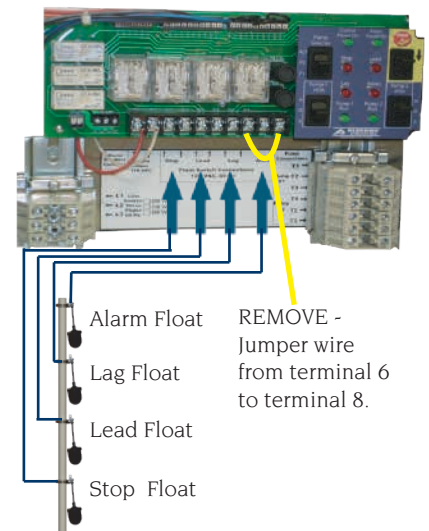

# Check It™ Panel

## Operation & Maintenance Manual - 3 Phase Duplex



### Circuit Board Command Center:

The control panel is equipped with a circuit board and control command center. There are two “HOA” switches, a pump selector switch and a Check It switch. Two green power “on” indicators provide visual indication for the control and alarm fuses. Fuses must be replaced with 1 amp fast acting 5mm x 20mm fuses. 4 red level indicators are provided for level indication of the off, lead, lag and alarm switches.

### HOA switch:



Placing the HOA switch in “H” (hand mode) will activate the pump. In the “O” (off) mode the pump will not activate. Placing the switch in “A” (automatic) mode, will activate the pump with the level switches. Place the switch in “A” mode when installation is complete and normal operation is desired.

### Pump selector switch:



Placing the switch in “ALT” will allow the panel to automatically alternate the pumps on successive cycles. If a pump needs to be taken out of service, place the switch to the pump that will remain in service. I.E. if pump 2 is out of service, place the switch to “P1” so the panel will activate pump 1 on each cycle. Note: If the level reaches the lag/alarm or alarm switch level the alarm will activate. For applications where alternation is not desired and a lag pump operation is required, consult factory for further information. When a pump is selected with the pump selector switch only that pump will activate (simplex mode).

### Check It switch:



Use the Check It switch to verify panel operation and float status. To check panel operation place the pump selector switch to “Alt” and the HOA switches to “A”. Press and hold the Check It switch – one pump should activate. De-Press the Check It switch and Re-Press again and the other pump should activate. The panel will alternate the pumps each time the Check It switch is pressed.

Use the Check It switch to verify float status. In normal operation the float status LED's activate when the level switch “closes”. If the floats are activated out of sequence (I.E., “off” float is not activated but the “lead” float is activated) the LED for the “lead” switch will not illuminate. Use the Check It switch to determine exact status of each float. When the Check It switch is pressed and held, the circuit will automatically give true indication of which level switches are “closed” or “opened”. You can perform this test with the “HOA” switch in either the “O” (off) or “A” (auto) modes.



# Check It™ Panel

## Operation & Maintenance Manual - 3 Phase Duplex

### Alarm Mode Configurations:

All “e” (economy) series control panels will only have a combination “test-normal-silence” switch where automatic alarm reset is the only alarm configuration. When the panel goes into alarm, press the switch to “silence” and the buzzer will turn off but the alarm indicator will remain on until the lag/alarm or alarm level switch deactivates and automatically resets the alarm system.

All other Check It series control panels employ separate “test” and “silence” switches. These panels can be field modified to have a “manual” alarm reset. Refer to figure for placement of an 18 AWG jumper wire to convert the panel from automatic reset to MANUAL reset. In the Manual Reset mode and when the panel goes into alarm, the panel will remain in alarm even if the alarm level switch is “opened” until the “silence” switch is activated. This feature allows alarms to be manually acknowledged before the alarm is cleared. In the event of a power failure, the alarm is also cleared. **WARNING!** When using the manual alarm reset feature you must use a four float system. If you’re using a 3 float system, add a fourth float and remove the yellow jumper wire between the lag and alarm terminals to avoid dry pumping.

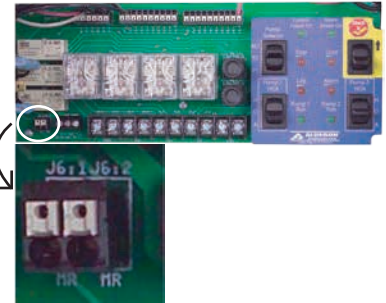

Use 18 AWG wire approximately 4” long. Strip off ¼” outer insulation. Insert jumper wire into the 2 position wire port (one wire per port). To remove jumper wire, press small screw driver or pointed object onto the “white” port block and remove wire as the wire is held in place by a spring cage terminal device.

### Circuit Board Terminal Blocks:

The Check It series control panel uses two terminal blocks. A 10 position main terminal block is for power and level switch connections. A separate 3 position terminal block are for dry auxiliary contacts. A 5 amp, 120 VAC max load can be applied to the auxiliary terminals. The auxiliary contacts are Form C, Single Pole, Double Throw. (Common, Normally Open, Normally Closed). Contacts change state when in alarm condition.

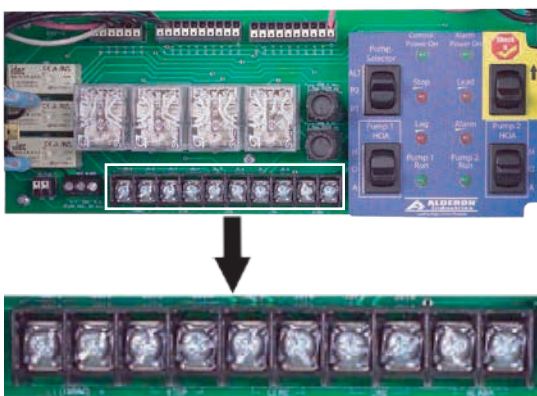

10 position terminal block



Auxiliary Contact terminal block



# Check It™ Panel

## Operation & Maintenance Manual - 3 Phase Duplex

### Description of Operation.

#### 3 Float:

With both "HOA" switches in "Auto" and the pump selector switch in "ALT": On water rise, the "off" float will close and when the level closes the "lead" float, pump 1 will start and pump down to the "off" float. The panel will alternate so on the next cycle pump 2 will activate. If the level reaches the "lag" float, both pumps and the alarm will activate and pump down to the "off" float. Alarm turns off at the "off" level. For a pump up application the floats are reversed (see float configurations Fig. #A).

#### 4 Float:

With both "HOA" switches in "Auto" and the pump selector switch in "ALT": On water rise, the "off" float will close and when the level closes the "lead" float, pump 1 will start and pump down to the "off" float. The panel will alternate so on the next cycle pump 2 will activate. If the level reaches the "lag" float, both pumps will activate and pump down to the "off" float. If it reaches the "alarm" float the alarm will activate. Alarm turns off when the alarm float is "off". For a pump up application the floats are reversed (see float configurations Fig. #B).

### Mounting Level Switches:

Float switches are most commonly used, but the Check It series control panels can be used with any dry contact type level or pressure switch. Illustrations show float switches and installed for pump down applications. Reverse float order for Pump Up applications. Refer to float switch instructions for mounting of pipe clamp or weighted floats.

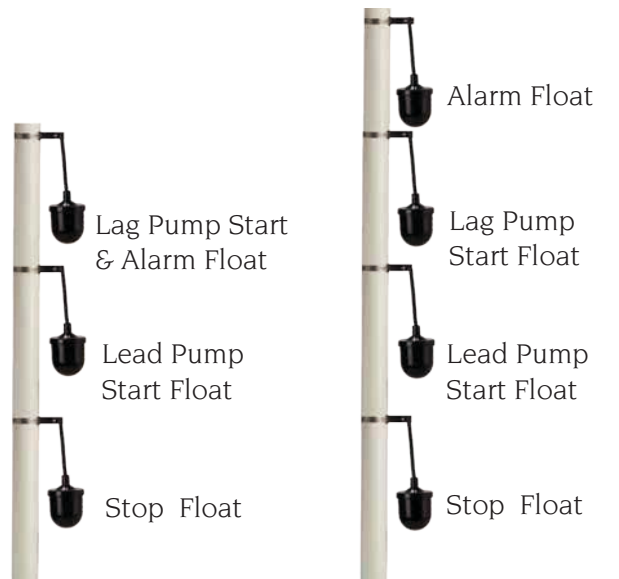

Fig. #A  
3 float configuration

Fig. #B  
4 float configuration

